



CT112&CT112A Series
Solar Pump Inverter User Manual

Content

Safety precautions.....	1
Chapter 1 System Introduction	6
Chapter 2 Solar Pump Inverter	7
Chapter 3 System Collection Diagram	15
Chapter 4 Function Parameters	27
Chapter 5 Troubles Shooting	40
Chapter 6 Warranty	44
Chapter 7 Communication protocol	45
User’s Information	53

Thank you for your using our solar pump inverter.

- Please read this manual thoroughly to ensure proper usage, keep this manual at an easily accessible place so that you can refer anytime as necessary.

Safety Precautions

Please read this operation manual carefully before installation, operation, maintenance or inspection.

In this manual, the safety precautions were sorted to “WARNING” or “CAUTION”.



WARNING

Indicates a potentially hazardous situation which, if not avoided, will result in death or serious injury.



CAUTION

Indicates a potentially hazardous situation which, if not avoided, will result in minor or moderate injury and physical damage. This sign is also used for alert of any un-safety operation.

In some cases, the contents of “CAUTION” could cause serious accident. Please follow these important precautions in any situation.

★**NOTE** is the necessary step to ensure the proper operation.

Warning Marks were shown on the front keypad of inverters.

Please follow these indications when using the inverter.

1. WARNING

- **May cause injury or electric shock.**
- **Please follow the instructions in the manual before installation or operation.**
- **Disconnect all power line before opening front cover of unit. Wait at least 5 minute until DC Bus capacitors discharge.**
- **Use proper grounding techniques.**
- **Never connect AC power to output UVW terminals**

Before installation



- Do not operate the inverter if there are any signs of water in the inverter when unpacking.
- Do not operate the inverter if there is any damage or components loss to the inverter when unpacking. Otherwise, physical injury or damage to the devices may occur.
- Do not touch the control terminals, PCB board or components inside the inverter with hands or body.



- Do not operate the inverter if the packing list is not consistent with the devices.
- Do not operate the inverter if the information on the name plate is not consistent with your order.

2. Installation



- Only qualified electricians are allowed to perform the installation, otherwise electric shock may occur.
- Please install the inverter on fire-retardant materials and keep the inverter away from combustible materials, otherwise a fire may occur.
- Please assemble and tighten the mounting screws of the inverter according to the regulations, otherwise the inverter may fall off.
- Do not install the inverter in explosive atmospheres, otherwise an explosion may occur.



- Handle the inverter with care to prevent it falling off and thus leading to injury to your feet or the device.
- Keep the inverter away from the places with large vibrations, water drops and direct sunlight.
- When installing the inverter in the cabinet, especially two or more inverters are installed in a cabinet, please pay attention to the installation space and ventilation.
- Avoid screws, cables and other conductive matters falling into the inverter during installation.

3. Wiring



- Only qualified electricians are allowed to perform the wiring, otherwise electric shock or device damage may occur.
- Carry out wiring strictly in accordance with this manual, otherwise there is a risk of electric shock or device damage.
- Ensure any input power supply is disconnected before wiring, otherwise electric shock may occur.
- Please select all cables, circuit breakers and contactors meeting the national standards as required by the manual.
- The inverter must be grounded reliably, otherwise electric shock may occur.
- Carry out wiring strictly in accordance with the silk printing instructions and avoid connecting the input and output wires reversely, otherwise the damage to the devices may occur.



- Keep the terminal signal cables of the inverter away from the power cables as far as possible, or distribute the two categories of cables vertically-crossed if the distance is not far enough, otherwise it may cause signal interference.
- Ensure that all the screws are tightened when wiring, otherwise damage to the inverter may occur.

» The encoders and sensors should be applied with the shielded cables and the shielded layer should be grounded reliably.

4. Operation



- Confirm that the wiring is completed and correct and then cover the plate before power on.
- Do not open the plate after power on, otherwise electric shock may occur.
- Operate the inverter appropriately, otherwise damage to the inverter may occur.
- Non-professionals are not allowed to test the signals when the inverter is running. Otherwise, physical injury or damage to the devices may occur.
- Any arbitrary change in parameters of the inverter is prohibited, otherwise damage to the inverter may occur.



- Do not touch the fans and brake resistors, otherwise it may cause mechanical injury or burn.
- Do not start up or stop the inverter by power on or off, otherwise damage to the inverter may occur.
- Ensure that the circuit breakers or contactors at the output sides of the inverter are not in output state before switching, otherwise damage to the inverter may occur.

5. Others



- This inverter is not suitable for the occasions when the specifications exceed those specified in this manual. If you have special requirements, please contact our technical department.
- The inverter is equipped with surge suppressors inside, which can protect it from the lightning. It is necessary to mount external surge suppressors at the power input side of the inverter in high lightning incidence areas.
- When the conductors between the inverter and the motor exceed 100m, it is recommended to mount the output reactors to avoid overcurrent caused by excessive distributed capacitance.
- Do not mount the compensation capacitors and the surge absorbers at the output sides of the inverter. Otherwise, it may cause damage to the inverter due to overheating.
- Mounting the input or output reactors, special filters and magnetic rings at the input or output sides of the inverter can effectively reduce the noise and thus avoid interference to other devices.
- Non-professionals are not allowed to perform withstand voltage tests on the inverter, , otherwise damage to the inverter may occur.
- Deal with the devices as industrial effluent after scrapping. Burning is strictly prohibited, otherwise an explosion may occur.
- The cooling effect of the inverter is reduced and the electrolytic capacitor electrolyte is also volatile in high altitude areas, which will shorten the life of the inverter. Check the altitude of the actual usage site is below 1000m. If exceeds, reduce rated output current by 1% for every additional 100m.

Chapter 1 System Introduction

1.1 Brief Introduction

A complete solar Pump system consist of solar array, pump and solar Pump inverter. The inverter can convert DC power from solar PV array to AC power to run pump motors.

Solar array, an aggregation of many solar modules connected in series and parallel, absorbs sunlight radiation and converts it into electrical energy, providing dynamical water for the whole system.

Inverter controls the system operation and adjust the output frequency in real-time according to the variation of sunlight intensity to realize the maximum power point tracking (MPPT).

Pump, drive by 3-phase or single phase AC motor, can draw water from the deep wells or rivers and lakes to pour into the storage tank or reservoir, or directly connect to the irrigation system, fountain system, etc.

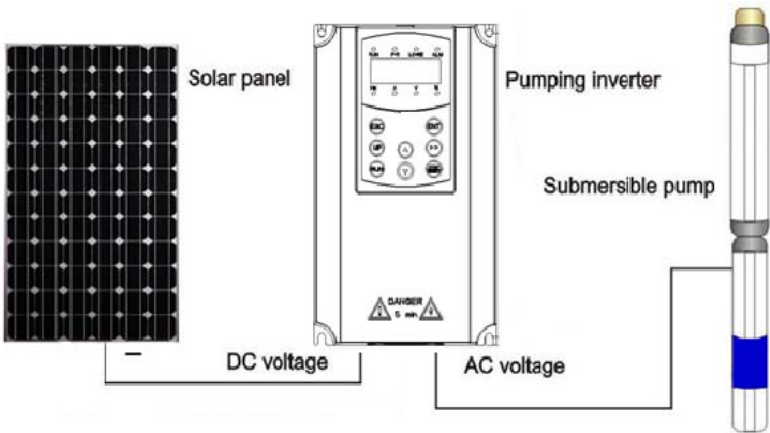
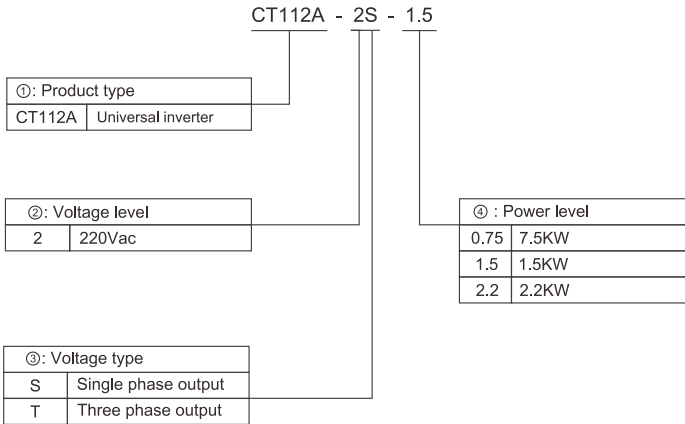
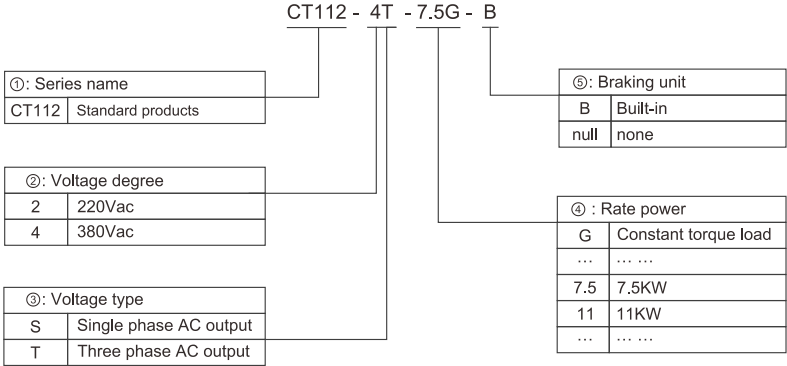

Figure 1 Structure of solar Pump system

Chapter 2 Solar Pump Inverter

2.1 Model Description

Model numbers on name plate consist of numbers, symbols, and letters, to express its respective series, suitable power type, power level and other information.



2.2 Name plate

MODEL:	CT112-4T-7.5G	
POWER:	7.5KW	
INPUT:	DC 300V~780V	
OUTPUT:	AC 3PH 0V~380V 0Hz~50Hz 18.5A	
S/N:	<input style="width: 100%; height: 20px;" type="text"/>	

MODEL:	CT112A-2T-2.2	
POWER:	2.2KW	
DC Input:	Vmax.PV: 450V MPPT Range : 100V~400V Vmp Range : 100V~400V	
AC Input:	1PH 220V~240V 47Hz~63Hz 24A	
AC Output:	0V-220V 1Hz~400Hz 14A(1PH)/10A(3PH)	
S/N:	<input style="width: 100%; height: 20px;" type="text"/>	

2.3 Parameters

2.3.1 CT112 series parameters

CT112 Solar Pump Inverter								
Model	Rated Power (KW)	DC Input VOC Voltage(V)	Recommend VOC Voltage (V)	Recommend MPPT Voltage (V)	Max. DC Input Current (A)	Rated Output Current(A)	Rated output Voltage(V)	Output Frequency (Hz)
CT112-2S-0.7G	0.75	300~450	388~450	320~370	8.5	5.5	1PH 220	0-50/60
CT112-2S-1.5G	1.5	300~450	388~450	320~370	14	10	1PH 220	0-50/60
CT112-2S-2.2G	2.2	300~450	388~450	320~370	23	13.8	1PH 220	0-50/60
CT112-2S-4.0G	4	300~450	388~450	320~370	35	20	1 PH 220	0-50/60
CT112-2T-0.7G	0.75	200~450	388~450	320~370	8.5	4.5	3PH220	0-50/60
CT112-2T-1.5G	1.5	200~450	388~450	320~370	14	7.0	3PH220	0-50/60
CT112-2T-2.2G	2.2	200~450	388~450	320~370	23	10	3PH220	0-50/60
CT112-2T-4.0G	4	200~450	388~450	320~370	35	16	3PH220	0-50/60
CT112-2T-5.5G	5.5	200~450	388~450	320~370	50	20	3PH220	0-50/60

CT112-4T-0.7G	0.75	300~780	670~780	540~630	8.5	2.5	3PH380	0-50/60
CT112-4T-1.5G	1.5	300~780	670~780	540~630	8.5	3.7	3PH380	0-50/60
CT112-4T-2.2G	2.2	300~780	670~780	540~630	14	5.3	3PH380	0-50/60
CT112-4T-4.0G	4.0	300~780	670~780	540~630	23	9.5	3PH380	0-50/60
CT112-4T-5.5G	5.5	300~780	670~780	540~630	23	14.0	3PH380	0-50/60
CT112-4T-7.5G	7.5	300~780	670~780	540~630	35	18.5	3PH380	0-50/60
CT112-4T-11G	11	300~780	670~780	540~630	35	25.0	3PH380	0-50/60
CT112-4T-15G	15	300~780	670~780	540~630	50	32.0	3PH380	0-50/60
CT112-4T-18.5G	18.5	300~780	670~780	540~630	50	38.0	3PH380	0-50/60
CT112-4T-22G	22	300~780	670~780	540~630	75	45.0	3PH380	0-50/60
CT112-4T-30G	30	300~780	670~780	540~630	75	60.0	3PH380	0-50/60
CT112-4T-37G	37	300~780	670~780	540~630	100	75.0	3PH380	0-50/60
CT112-4T-45G	45	300~780	670~780	540~630	100	92.0	3PH380	0-50/60
CT112-4T-55G	55	300~780	670~780	540~630	150	115.0	3PH380	0-50/60
CT112-4T-75G	75	300~780	670~780	540~630	225	150.0	3PH380	0-50/60
CT112-4T-90G	90	300~780	670~780	540~630	300	180.0	3PH380	0-50/60
CT112-4T-110G	110	300~780	670~780	540~630	375	215.0	3PH380	0-50/60
CT112-4T-132G	132	300~780	670~780	540~630	450	260.0	3PH380	0-50/60

CT112-2S-0.4G ~4.0G	Input specification	Maximum Input PV Voltage (PV Open-Circuit Voltage)	450VDC
		Recommended MPPT Voltage Range	320~370VDC(Vmp)
		Recommended Input Operation Voltage	388~450VDC (VOC)
	Input specification (Grid or backup generator input)	Input voltage	1PH 220V(-15%~30%)
	Output specification	Rated output voltage	1PH 220V
		Output frequency	0~600.00Hz (default: 0~ 60.00Hz)
Fault protection	Built-in Protection	Protection of light load, over-current, over-voltage, output phase-lose, under-load, under-voltage, short circuit, overheating, water pump run dry etc.	
CT112-2T-0.7G ~5.5G	Input specification (PV Input)	Maximum Input PV Voltage (PV Open-circuit Voltage)	450VDC
		Recommended MPPT Voltage Range	320~370VDC(Vmp)
		Recommended Input Operation Voltage	388~450VDC (VOC)
	Input specification (Grid or backup generator input)	Input voltage	1PH 220V(-15%~30%)

	Output specification	Rated output voltage	3PH 220V
		Output frequency	0~600.00Hz (default: 0~60.00Hz)
	Fault protection	Built-in Protection	Protection of light load, over-current, over-voltage, output phase-lose, under-load, under-voltage, short circuit, overheating, water pump run dry etc.
CT112-4T-0.7G ~132G	Input specification(PV Input)	Maximum Input DC Voltage (PV Open-circuit Voltage)	780VDC
		Recommended MPPT Voltage Range	540~630VDC(Vmp)
		Recommended Input Operation Voltage	670~780VDC (VOC)
	Input specification(Grid or backup generator input)	Input Voltage Range	Three phase 380VAC(-15%~30%)
	Output specification	Rated output voltage	3PH 380VAC
		Output frequency	0~600.00Hz (Default 0~60.00Hz)
	Fault protection	Built-in Protection	Protection of light load, over-current, over-voltage, output phase-lose, under-load, under-voltage, short circuit, overheating, water pump run dry etc.
Keypad display	LED display	Highlight LED digital tube displays the inverter information	
	LCD display	LCD displays inverter information	
Others	Application Site	No direct sunshine, no dust, corrosive gas, combustible gas, oil mist, steam, dripping or salinity etc.	
	Altitude	0~2000m, Derated use above 1000m,per100m, the rated output current decrease 1%.	
	Environment Temperature	-10°C~50°C (Environment Temperature be 40°C~50°C, please keep derated use.)	
	Humidity	5~95%,non-condensation	
	Vibration	less than 5.9 m/s ² (0.6g)	
	Storage Temperature	-20°C~+70°C	
	Efficiency	Rated Power Run≥93%	
	Installation	Wall or rail mounting	
Cooling	Forced Air Cooling		

2.3.2 CT112A series parameters

CT112A Solar Pump Inverter			
CT112A-2S/2T-XXX	0.7	1.5	2.2
Rated output power(kW)	0.7	1.5	2.2
Max. DC input current (A)	9	12	12
Rated AC input current—AC type (A)	9.3	15.7	24
Rated output current (A)	4.5	10	14

Note: Output current is defined as rated value at single 220V output voltage, and output current at three phase output is counted additionally according to the power.

Mode	CT112A-2S-0.7	CT112A-2S-1.5	CT112A-2S-2.2
	CT112A-2T-0.7	CT112A-2T-1.5	CT112A-2T-2.2
DC INPUT			
Max. DC voltage(V)	450		
Starting voltage(V)	80	100	
Min. Operation voltage(V)	60	80	
Recommended MPPT voltage(V)	80~400	100~400	
Input channel	One channel:MC4		
Max. DC input current(A)	9	12	
Bypass AC input (model supports mains input)			
Input voltage(Vac)	220/230/240(1PH) (-15%~+10%)		
Input frequency (Hz)	47~63		
AC input terminal	1P2L		
AC output			
Rated (W)	750	1500	2200
Rated current (A)	5.1 (1PH) 4.2 (3PH)	10.2 (1PH) 7.5 (3PH)	14 (1PH) 10 (3PH)
Output voltage(Vac)	0~input voltage		
Output wiring mode	1P2L/2P3L/3P3L		
Output frequency (Hz)	1~400		
Control performance			
Control mode	MPPT		
Motor type	Asynchronous motor		
Other parameters			
Dimension (L*W*H) (mm)	314*280*128		
Protection level	IP54		
Cooling mode	Natural cooling		
HMI	External LED keypad		
Communication terminal			
External communication	RS485/3 digital inputs		
Operation environment			
Ambient temperature	-25°C~60°C (derate when the temperature is above 45°C)		
Operation altitude	3000 m (derate when the altitude is above 2000m)		
Warranty	18 months		

2.4 External Dimensions

2.4.1 CT112 series solar pump inverter

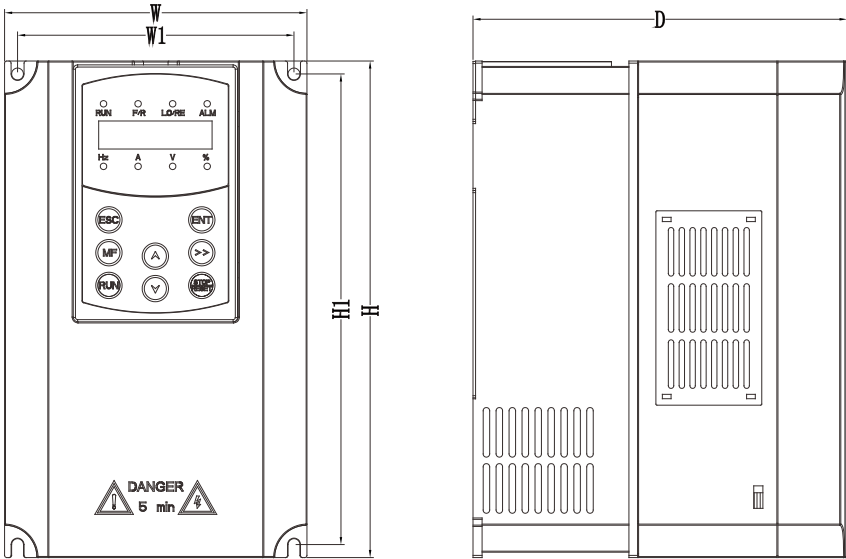

Figure 2 Dimensions (CT112:11KW and below)

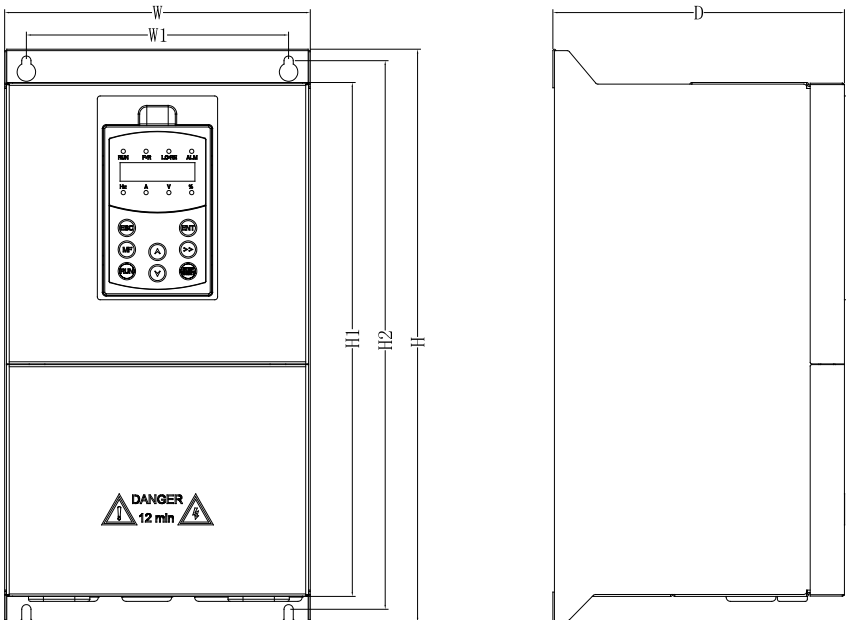

Figure 3 Dimensions(CT112:15KW~132KW)

Table 1 Dimensions of CT112 series inverter

Power(kw)	Size (mm)						Installation Hole(mm)	Weight (kg)	Shape of Inverter
	W	H	D	W1	H1	H2			
CT112-2S-0.4G	126	186	155	115	175	---	5	1.6	C0
CT112-2S-0.7G									
CT112-2S-1.5G									
CT112-2S-2.2G									
CT112-2S-4.0G	140	230	172	128	218	---	5.5	3.5	C1
CT112-2T-0.7G	126	186	155	115	175	---	5	1.6	C0
CT112-2T-1.5G									
CT112-2T-2.2G									
CT112-2T-4.0G	140	230	172	128	218	---	5.5	3.5	C1
CT112-2T-5.5G	165	285	200	153	273	---	5.5	5.5	C2
CT112-4T-0.7G	126	186	155	115	175	---	5	1.6	C0
CT112-4T-1.5G									
CT112-4T-2.2G									
CT112-4T-4.0G	140	230	172	128	218	---	5.5	3.5	C1
CT112-4T-5.5G									
CT112-4T-7.5G	165	285	200	153	273	---	5.5	5.2	C2
CT112-4T-11G									
CT112-4T-15G	214	402	205	184	360	385	7	11.5	C3
CT112-4T-18.5G									
CT112-4T-22G									
CT112-4T-30G	250	442	230	220	405	425	7	19	C4
CT112-4T-37G									
CT112-4T-45G	299	602	276	240	540	580	9	30	C5
CT112-4T-55G									
CT112-4T-75G	329	660	332	250	601	640	9	56	C6
CT112-4T-90G									
CT112-4T-110G									
CT112-4T-132G									

2.4.2 CT112A solar pump inverter

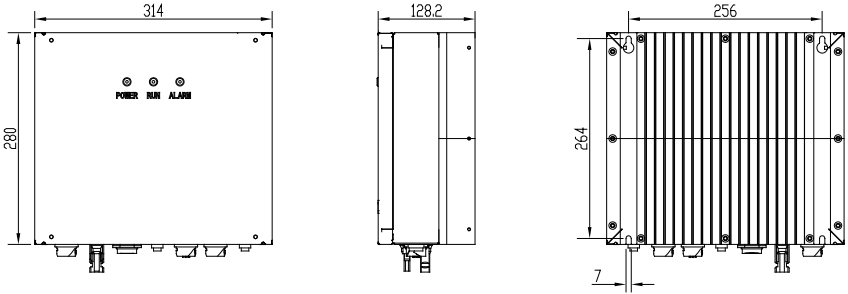

Figure 4 CT112A series dimension diagram

Table 2 Dimensions of CT112A series inverter

Mode	Height H1 (mm)	Width W1 (mm)	Depth D (mm)	Height H2 (mm)	Width W2 (mm)	Installation hole
CT112A-2S/2T-0.7	280	314	128.2	264	256	M6
CT112A-2S/2T-1.5						
CT112A-2S/2T-2.2						

Chapter 3 System Collection Diagram

3.1 CT112 Series Main Circuit Terminals

3.1.1 Schematic Diagram for Connection of Main Circuit Terminals

① Connection diagram of main circuit for the inverter of 220v



② Connection diagram of main circuit for the inverter of 380v 0.7~22KW

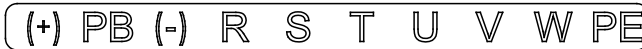

③ Connection diagram of main circuit for the inverter of 380v 30~37KW

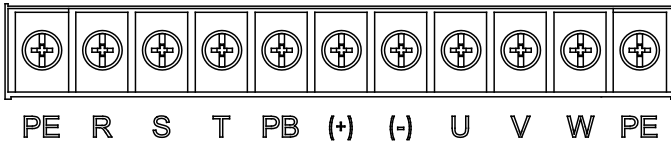

④ Connection diagram of main circuit for the inverter of 380v 45~55kw

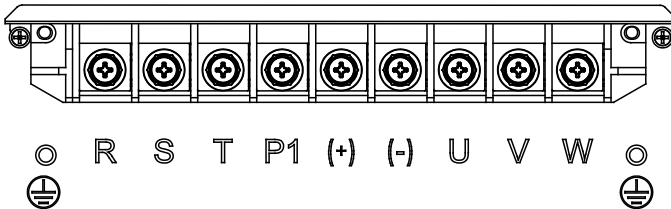

⑤ Connection diagram of main circuit for the inverter of 380v 75~132kw

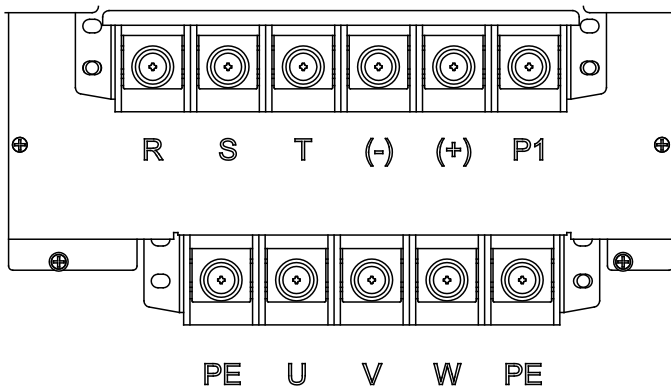

3.1.2 Instructions of Main Circuit Terminals of Inverter:

Terminal	Description
R、 S、 T	Terminals of 3 phase AC input
(+)、 (-)	Terminals of 2 phase DC input
(+)、 PB	Spare terminals of external braking resistor
P1、 (+)	Spare terminals of external DC reactor
(-)	Terminal of negative DC bus
U、 V、 W	Terminals of 3 phase AC output
	Terminal of ground

Danger

- the voltage class of CT112 series inverter 3phase power has 2 class: 220V, 380V, before connecting power, please make sure the power class on inverter nameplate is the same with the accessing power. Otherwise do not connect.
- DC bus (+) (-)terminal: take note that when power outage there is residual voltage on DC bus P+ P- terminal, need to wait for a while until CHARGE LED off. Otherwise it is danger of electric shock.
- When selecting external brake unit, note the polarity of P= (+) and (-) cannot be reversely connected, otherwise it can result in damage or even fire.

Do not directly connect brake resistor to DC bus, it may result damage or fire.

Warning

- 1)Input power L,N or R, S T: the cable connection at input side of the inverter has no phase sequence requirement.
- 2)Brake unit cable length should not exceed 10m, twisted pair or double cable parallel wiring should be used.
- 3)Brake resistor connecting terminal (+) (-): confirm whether the device has built-in brake unit, its brake resistor connecting terminal is effect. The brake resistor selection table 2-4 recommending value and the wiring distance should less than 5M.

Other it can damage inverter.

- 4) External DC electric reactor connecting terminal P1 (+): for external DC reactor to 45Kw and above power inverter, get rid off the connector between P1 (+) terminal during installation, reactor is installed between the 2 terminal.
- 5) Inverter output side U V W: the output side cannot connect capacitor or surge absorber, otherwise it will affect inverter in self-protection frequently or damage.
- 6) In case the motor cable is too long, it may generate electrical resonance easily due to the impact of distributed capacitance, thus damaging the motor insulation or generating higher leakage current to invoke over current protection of the inverter. When the length of motor cables longer than 100 meters, it needs to install a AC output reactor.
- 7) Earth terminal PE:
This terminal shall be earthed reliably, with resistance of earth cable of less than 10Ω. Otherwise, it may cause fault or damage the inverter.
Do not share the earth terminal with zero line R,S,T terminal, otherwise it will result equipment abnormal running or damage.

3.1.3 Control Circuit Terminal

Terminal	Description
DI1~DI5	ON-OFF signal input, optical coupling with PW and COM. Input voltage range: 9~30V Input impedance: 3.3kΩ
PW	External power supply. +24V terminal is connected to PW terminal as default setting. If user need external power supply, disconnect +24V terminal with PW terminal and connect PW terminal with external power supply.
+24V	Provide output power supply of +24V. Maximum output current: 150mA
AIN	Analog input, 0~10V/ 0~20mA Input impedance: 10kΩ
GND	Common ground terminal of analog signal and +10V. GND must isolated from COM.
COM	Common ground terminal for digital signal and +24V (or external power supply).
+10V	Supply +10V for inverter.
PE	Ground Terminal.
T1A, T1B, T1C	RO1 relay output: RO1A—common; RO1B—NC; RO1C—NO. Contact capacity: AC 250V/3A, DC 30V/1A.
T2A, T2C	RO2 relay output: RO2A—common; RO2C—NO. Contact capacity: AC 250V/3A, DC 30V/1A.

3.2 CT112A Main Circuit Terminals

3.2.1 Terminals description of CT112A

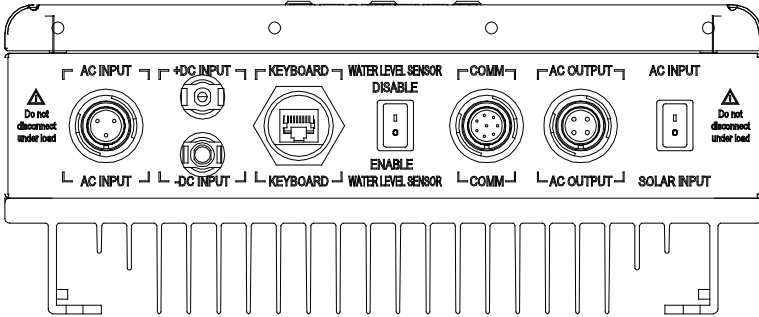

No	Terminal name	Pin definition	
1	AC input terminal	1. L	
		2. N	
		3. PE	
2	PV input terminal: negative	-DC INPUT	
3	PV input terminal: positive	+DC INPUT	
4	External keypad terminal	RJ45	
5	Water level indication switch	1. DI3	Short circuit: water shortage. Direct short-circuit running without water level sensor
		2.COM	
6	Functional terminal	1. 485+	
		2. 485-	
		3. DI2	Short circuit: full water
		4. DI3	Short circuit: water shortage
		5. COM	
		6. AIN	Pressure sensor
		7. +24V	
		8. PE	
7	AC output terminal	1. U	
		2. V	
		3. W	
		4. PE	
8	Solar/mains switch	1. DI4	Solar restrict switch, F05.04=42, DI4 setting
		2. COM	

3.2.2 Power terminal description

3.2.2.1 Terminal 1 is AC input terminal, which is involved in the model supports mains input.

Live wire of the grid links with L, neutral wire links with N, earth wire links with PE.

(Attention: make sure PE is connected reliably for safety)

3.2.2.2 Terminal 7 is AC output terminal to connect water pump motor. When three phase motor is used, please connect the U, V, W three phase of the motor to U, V, W of solar Pump inverter, motor frame connects PE pin of terminal 7.

3.2.2.3 If single phase motor is used, there are two wiring methods according to different control modes.

(1) Single phase control method: connect the phase wire of single phase motor to U, W of the inverter terminal 7, motor frame connects PE pin of terminal 7. This method doesn't need to disassemble the motor starting capacitor, convenient wiring but bad starting performance makes that it's only applicable for some single-phase motors.

(2) Two phase control method: this method needs to disassemble starting capacitor and running capacitor (if existed) of the motor. Internal wiring of normal single-phase motor is as below, L1 is running winding, L2 is starting winding, C1 is running capacitor, C2 is starting capacitor. When the speed of motor is beyond 75% of rated speed, starting capacitor breaks off through centrifugal switch.

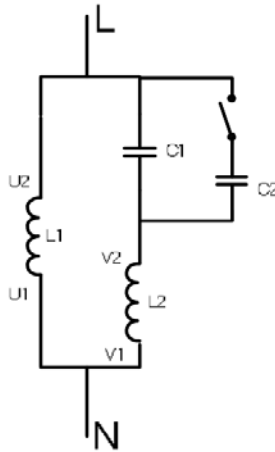

Disassemble the starting capacitor and running capacitor, internal wiring of single phase motor winding is as below:

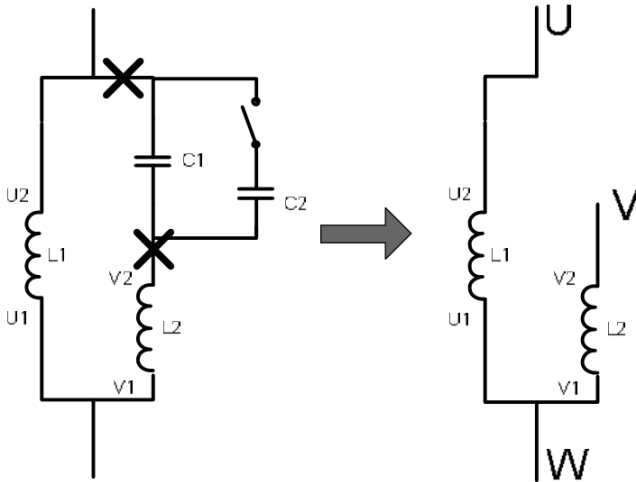

U1 and V1 are common ends of winding to connect with W phase output of solar Pump inverter, connect U2 end of running winding to U phase output and connect V2 of starting winding to V phase output.

After adjustment of positive way, change the running direction by F00.13 as same with positive/negative way control of three phase motor.

3.2.3 Communication terminal description

Terminal name	Description	
PE	Grounding terminal	
COM	+24V common terminal	
DI2	Switch input 2	1. Internal impedance:3.3kΩ 2. Acceptable 12~30V voltage input 3. Single-way input terminal, only supports NPN wiring. 4. Maximum input frequency:1kHz 5.Programmable digital input terminal, user can set terminal functions by function codes. 6. DI1 short circuit with COM by default internally, no leading outwards.
DI3	Switch input 3	
DI4	Switch input 4	
485+	485 communication interface,485 differential signal interface, standard	
485-	485 communication port connects in twisted pair cable or shielded cable.	

3.3 Collection Diagram for Different Motor

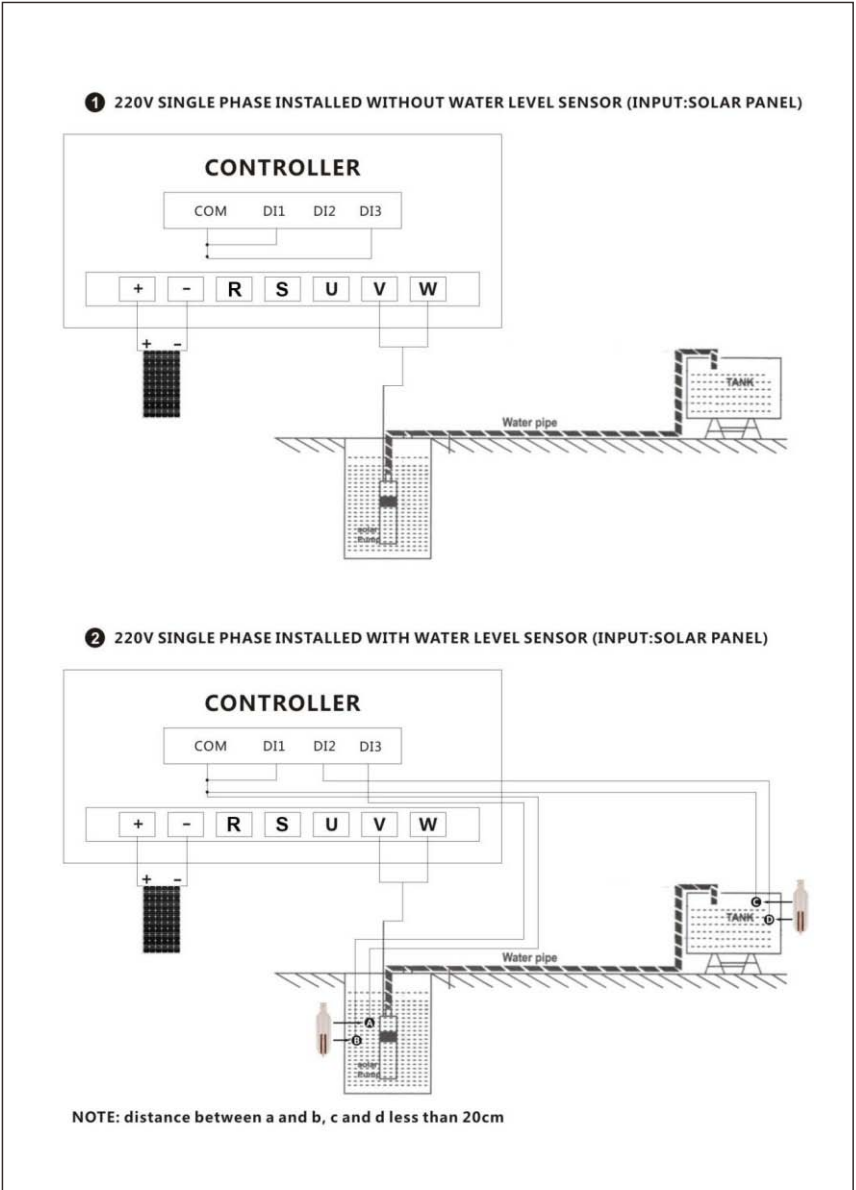

Figure 4 Diagram of single phase inverter connection method (PV Input)

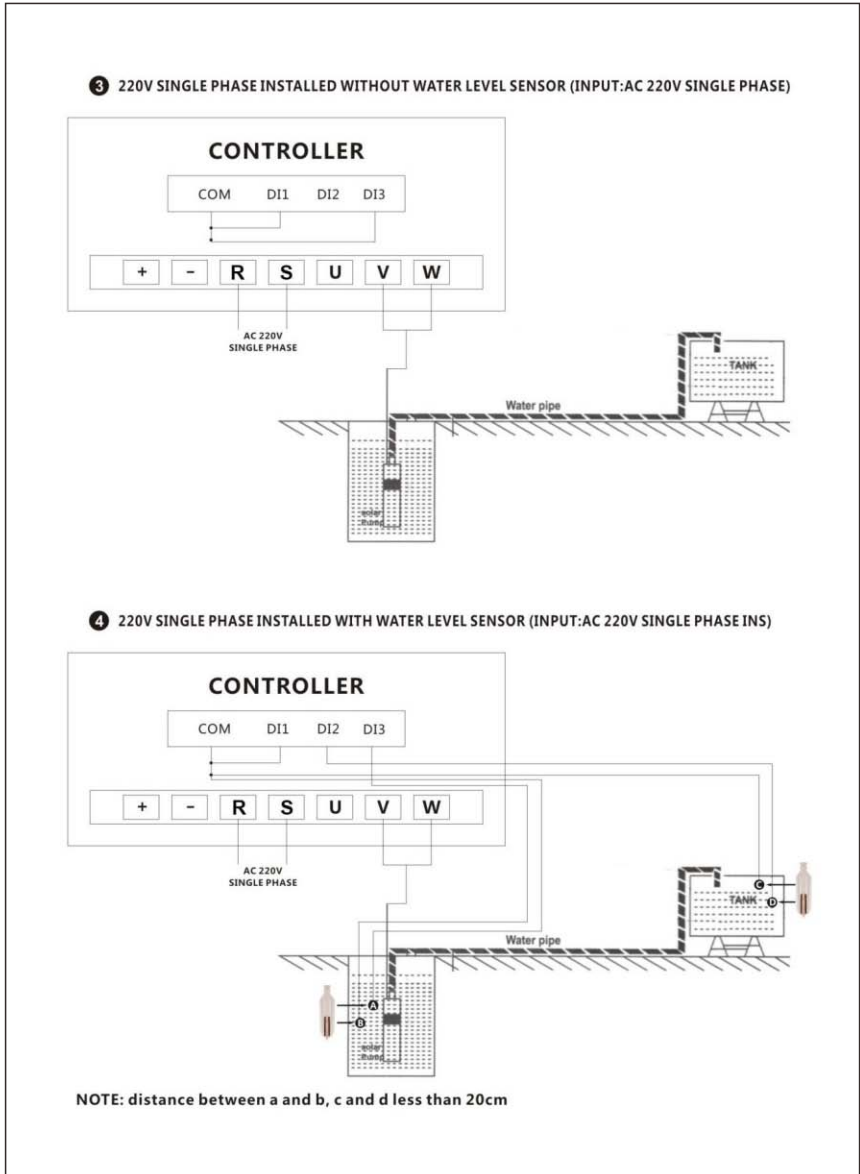

Figure 5 Diagram of single phase inverter connection method (AC Input)

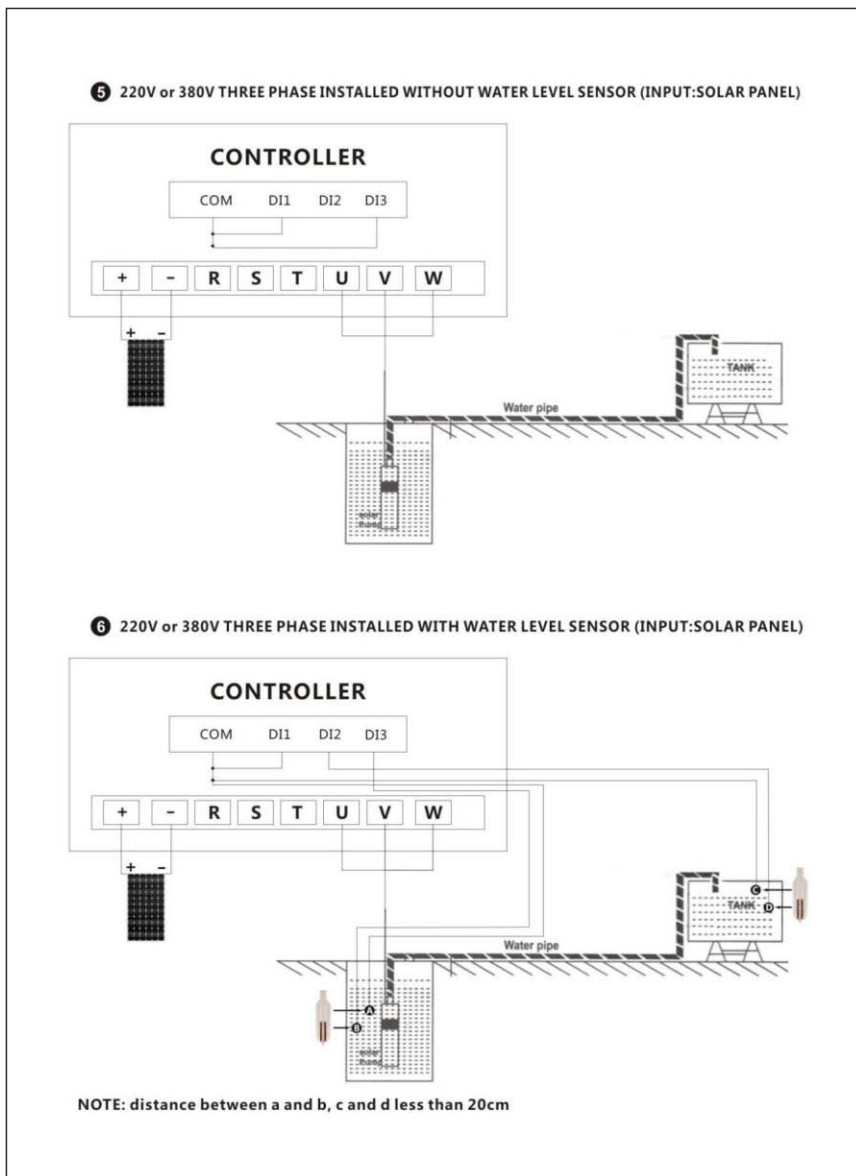

Figure 6 Diagram of 3phsae inverter connection method (PV Input)

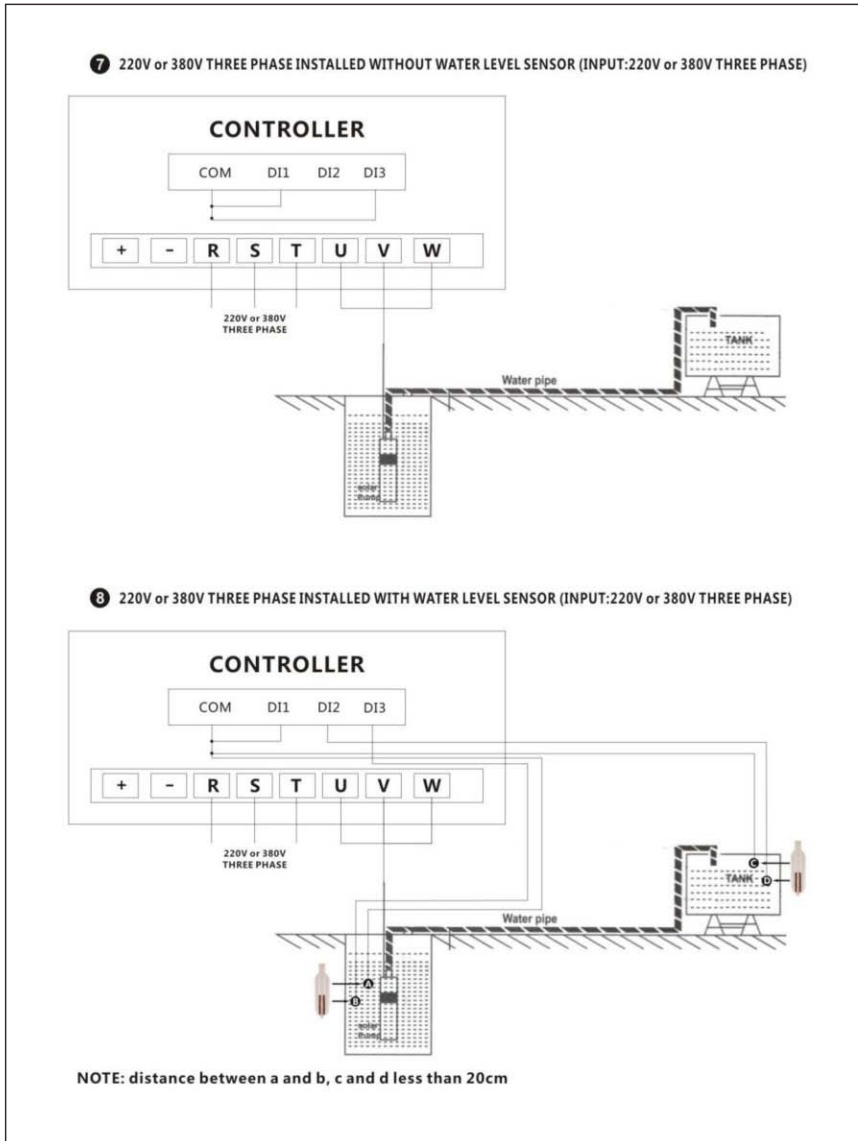

Figure 7 Diagram of 3phase inverter connection method (AC Input)









Note : If no need water level sensor of tank , please don't connect 'DI2' , 'COM' .
If you want to operate inverter by hand , no run/stop automatically , please don't connect 'DI1' , 'COM'.

3.4 Keypad operation procedure

3.4.1 Keypad induction

The keypad consists of three parts for unit/status LEDs display, parameters display and key operation as shown below.

3.4.2 Operation panel button and potentiometer function

Button	Name	Description
	Programming Key	Entry or escape of first-level menu.
	Enter Key	Progressively enter menu and confirm parameters.
	UP Increment Key	Progressively increase data or function codes.
	DOWN Decrement Key	Progressive decrease data or function codes.
	Shift Key	In parameter setting mode, press this button to select the bit to be modified. In other modes, cyclically displays parameters by right shift
	Run Key	Start to run the inverter in keypad control mode.
	STOP/RESET Key	In running status, restricted by F05.05, can be used to stop the inverter. When fault alarm, can be used to reset the inverter without any restriction.
	Shortcut Key	Determined by Function Code F05.04 0: Jog operation 1: Switch between forward and reverse 2: Clear the UP/DOWN settings. 3: Quick debugging mode1 (by menu) 4: Quick debugging mode2 (by latest order) 5: Quick debugging mode3 (by non-factory setting parameters)

3.4.3 Indicator of Light Description

3.4.3.1 Unit Indicator Light Description

Light	Unit indicator	Description
Status Light	RUN	Light on : Run Light off: Stop Flash: Sleeping mode
	F/R	Light on: Reverse Light off: Forward
	LO/RE	Light on: Communication control; Light off: Keypad control Flash: Terminal control
	ALM	Light on : Fault alarm; Light off: No fault alarm Flash: Overload warning
Units Light	Hz	Frequency unit
	A	Current unit
	V	Voltage unit
	RPM	Rotating speed unit
	%	Percentage

3.4.3.2 Keypad Display Description

Displayed word	Meaning	Displayed word	Meaning	Displayed word	Meaning	Displayed word	Meaning
	0		1		2		3
	4		5		6		7
	8		9		A		b
	C		d		E		F
	H		I		L		N
	o		P		S		T
	U		V		.		

Chapter 4 Function Parameters

4.1 The Basic Function Parameters

The symbols in the function code table are described as follows:

"○" means the value of this parameter can be modified in stop and running status of drive;

"☆" means the value of this parameter cannot be modified when drive is running;

"●" means this parameter is a measured value that cannot be modified;

Default: The value when restored to factory default. Neither measured parameter value nor recorded value will be restored.

Setting Range: the scope of setting and display of parameters.

Code	Name	Description	Factory Default	Attribute
F00 Group: Basic function				
F00.01	Command Source Selection of Run/Start	0: Operation Panel (LED off) 1: Terminal Panel (L/R on) 2: Computer Communications (L/R flash)	1	○
F00.03	Maximum frequency	F00.04~600.00Hz	50.00Hz	☆
F00.04	Upper frequency limit	F00.05~F00.03	50.00Hz	☆
F00.05	Lower frequency limit	0.00 Hz~F00.04	0.00Hz	☆
F00.06	Frequency setting	0: keypad digital setting 1: analog AI1 setting	0	○
F00.11	Acceleration Time 0	0.0s~3600.0s	Model Set	○
F00.12	Deceleration Time 0	0.0s~3600.0s	Model Set	○
F00.13	Run direction	0: positive 1: reverse 2: prohibit reverse	0	☆
F00.14	Carrier frequency set	1.0~15.0kHz	Model Set	○
F00.17	Inverter type	0: G type 1: P type	0	☆
F00.18	Restore parameters	0: No action 1: Restore factory setting 2: Clear fault records	0	☆
F01 Group: Start and stop control				
F01.01	Starting frequency	0.00~50.00Hz	0.50Hz (CT112-4T) 20.00Hz (CT112-2S) 0.00Hz (CT112A)	☆
F01.02	Hold time of starting frequency	0.0~50.0s	0.0s	☆

Code	Name	Description	Factory Default	Attribute
F01.08	Stop mode selection	0: Deceleration stop 1: Freewheel stop	0 (CT112) 1 (CT112A)	○
F01.13	Dead time of FWD/REV	0.0~3600.0s	0.0s	○
F01.14	Switch mode of FWD/REV	0: switch after zero frequency 1: switch after starting frequency 2: delay and switch after stop speed	0	○
F01.15	Stop speed	0.00~100.00Hz	10.00HZ (CT112) 0.50 Hz (CT112A)	○
F01.18	Terminal Control When Power-On	0: Terminal Command Enabled 1: Terminal Command Disabled	1	○
F01.19	Actuation when running frequency is less than lower limit frequency	0: run at lower limit frequency 1: stop 2: stand-by	0	☆
F01.20	Delay time of dormancy wake up	0.0~3600.0s	0.0s	☆
F01.21	Restart when Power-off	0: Forbid to Restart 1: Allow to restart	1	○
F01.22	Waiting time for restart after power-off	0.0~3600.0s	60.0s	○
F01.23	Delay time of start	0.0~60.0s	60.0s	○
F01.24	Wait Time of Restart When Power-off	0.0~100.0s	0.0s	○
F02 Group Motor parameter				
F02.00	Motor1 type	0: Asynchronous motor	0	●
F02.01	Motor 1 Rated Power	0.1kW~3000.0kW	Model Set	☆
F02.02	Motor 1 Rated Frequency	0.00Hz~F00.03	50.00Hz	☆
F02.03	Motor 1 Rated Rotational Speed	1RPM~36000RPM	Model Set	☆
F02.04	Motor 1 Rated Voltage	0V~1200V	Model Set	☆
F02.05	Motor 1 Rated Current	0.8A~6000.0A	Model Set	☆
F02.06	Stator resistance of asynchronous motor	0.001~65.535 Ω	Model Set	○
F02.07	Rotor resistance of asynchronous motor	0.001~65.535 Ω	Model Set	○
F02.08	Inductance of asynchronous motor	0.1~6553.5mH	Model Set	○
F02.09	Mutual inductance of asynchronous motor	0.1~6553.5mH	Model Set	○
F02.10	Non-load current of asynchronous motor	0.1~6553.5A	Model Set	○

Code	Name	Description	Factory Default	Attribute
F02.26	Motor overload protection	0: no protection 1: ordinary motor(with low speed compensation) 2: variable frequency motor(without low speed compensation)	2	☆
F02.27	Motor overload protection factor	20.0~120.0%	100.0%	○
F03 Group: Reserved				
F04 Group: V/F control				
F04.00	V/F curve	0: straight line V/F curve 1: multi-dots V/F curve 2: 1.3 th power low torque V/F curve 3: 1.7 th power low torque V/F curve 4: 2.0 nd power low torque V/F curve 5: V/F separated curve	4	☆
F04.01	Motor 1 Torque Boost	0.0% (automatic)0.1%~10.0%	1.0%	○
F04.02	Motor 1 Torque Boost to Stop	0.0%~50.0%	20.0%	○
F04.03	V/F frequency 1	0.00Hz~F04.05	0.00Hz	○
F04.04	V/F voltage 1	0.0%~110.0% (motor rated voltage)	00.0%	○
F04.05	V/F frequency 2	F04.03~F04.07	00.00Hz	○
F04.06	V/F voltage 2	0.0%~110.0% (motor rated voltage)	00.0%	○
F04.07	V/F frequency 3	F04.05~F02.02 (motor rated frequency)	00.00Hz	○
F04.08	V/F voltage 3	0.0%~110.0% (motor rated voltage)	00.0%	○
F04.09	Slip compensation gain	0.0~200.0%	100.0%	○
F04.10	Low frequency surge suppression factor	00~100	10	○
F04.11	High frequency surge suppression factor	00~100	10	○
F04.12	Frequency threshold of surge suppression	0.00Hz~F00.03 (Max. frequency)	30.00 Hz	○
F04.27	Voltage setting	0: Keypad setting 1: AI1 voltage setting 2~10:Reserved	0	○
F04.28	Keypad setting voltage	0.0%~100.0%	100.0%	○
F04.29	Voltage ACC time	0.0s~3600.0s	5.0s	○
F04.30	Voltage DEC time	0.0s~3600.0s	5.0s	○
F04.31	Max. V/F separated voltage	F04.32~100.0%	100.0%	☆
F04.32	Min. V/F separated voltage	0.0%~F04.31	0.0%	☆

Code	Name	Description	Factory Default	Attribute
F04.33	Weak magnetic coefficient of constant power zone	1.00~1.30	1.00	○
F05 Group: Input terminal				
F05.01	Terminal DI1 Function Selection	0: disabled	1	☆
F05.02	Terminal DI2 Function Selection	1: forward run 2: reverse running 3: three-wire running	43	☆
F05.03	Terminal DI3 Function Selection	4: forward jogging 5: reverse jogging	44	☆
F05.04	Terminal DI4 Function Selection	6: freewheel stop 7: fault reset	42	☆
F05.05	Terminal DI5 Function Selection	8: emergency stop 9: external fault input 21: ACC/DEC time selection 1 22: ACC/DEC time selection 2 30: ACC/DEC disabled 36: switch command to keypad 36: switch command to terminal 36: switch command to communication 40: power consumption clear 41: power consumption stay 42: PV Inverter Forbid 43: Full-Water 44: Dry -Water	0	☆
F05.10	Terminal DI1~DI5 Positive/Negative Logic	0x00~0x1F	0x004	☆
F05.11	DI Terminal Filtering Time	0.000~1.000s	0.010s	○
F05.12	Virtual terminal setting	0:virtual terminal invalid 1:MODBUS communication virtual terminal valid	0	☆
F05.13	Terminal control running mode	0: two-wire control mode 1 1: two-wire control mode 2 2: three-wire control mode 1 3: three-wire control mode 2	0	☆
F05.14	Delay time of DI1 on	0.000~50.000s	0.000s	○
F05.15	Delay time of DI1 off	0.000~50.000s	0.000s	○
F05.16	Delay time of DI2 on	0.000~50.000s	0.000s	○
F05.17	Delay time of DI2 off	0.000~50.000s	0.000s	○
F05.18	Delay time of DI3 on	0.000~50.000s	0.000s	○
F05.19	Delay time of DI3 off	0.000~50.000s	0.000s	○
F05.20	Delay time of DI4 on	0.000~50.000s	0.000s	○
F05.21	Delay time of DI4 off	0.000~50.000s	0.000s	○
F05.22	Delay time of DI5 on	0.000~50.000s	0.000s	○
F05.23	Delay time of DI5 off	0.000~50.000s	0.000s	○

Code	Name	Description	Factory Default	Attribute
F05.32	AI1 lower limit	0.00V~F05.34	0.00V	○
F05.33	Corresponding setting of AI1 lower limit	-100.0%~100.0%	0.0%	○
F05.34	AI1 upper limit	F05.32~10.00V	10.00V	○
F05.35	Corresponding setting of AI1 upper limit	-100.0%~100.0%	100.0%	○
F05.36	AI1 input filter time	0.000s~10.000s	0.100s	○
F05.37	AI0 lower limit	0.00V~F05.39	0.00V	○
F05.38	Corresponding setting of AI0 lower limit	-100.0%~100.0%	0.0%	○
F05.39	AI0 upper limit	F05.37~10.00V	10.00V	○
F05.40	Corresponding setting of AI0 upper limit	-100.0%~100.0%	100.0%	○
F05.41	AI0 input filter time	0.000s~10.000s	0.100s	○
F06 Group: Output terminal				
F06.03	Relay T1 Output Function	0: Disabled 1: running	1	○
F06.04	RelayT2 Output Function	2: forward running 3: reverse running 4: jogging 5: inverter fault 6: frequency level detection FDT1 7: frequency level detection FDT2 8: frequency arrival 9: zero speed running 10: upper limit frequency arrival 11: lower limit frequency arrival 12: running ready 14: overload early warning 15: under-load early warning 20:external fault valid 22: running time arrival 23: MODBUS communication virtual terminal output	5	○
F06.05	Output Terminal Positive/Negative Logic	0x0~0x1F	0x0	○
F06.10	Relay T1 Output delay time	0.000~50.000	0.000s	○
F06.11	Relay T1 Disconnect delay time	0.000~50.000	0.000s	○
F06.12	Relay T2 Output Delay Time	0.000~50.000	0.000s	○
F.6.13	Relay T2 disconnect Delay Time	0.000~50.000	0.000s	○

Code	Name	Description	Factory Default	Attribute
F07 Group: HMI interface				
F07.00	User Password	0~65535	0	○
F07.02	MF key function selection	0:invalid 1: jogging running 2:left-shift key to switch display state 3: FWD/REV switch 4: clear UP/DOWN setting 5: freewheel stop 6: switch command methods in order 7: non-factory parameter debugging	1	☆
F07.03	MF key switch command method order	0: keypad →terminal→communication 1: keypad←→terminal 2: keypad←→communication 3: terminal←→communication	0	○
F07.04	STOP/RESET key stop function	0: only valid for keypad control 1: valid for keypad and terminal control at the same time 2: valid for keypad and communication control at the same time 3: valid for all control modes	0	○
F07.05	Running Status Display Selection	0x0000~0xFFFF BIT0: Output frequency BIT1: Reference frequency BIT2: DC bus voltage BIT3: Output voltage BIT4: Output current BIT5: Rotation speed BIT6: Output power BIT10: input terminal status BIT11: output terminal status	0x05F	○
F07.06	Running Status Display Selection 2	0x0000~0xFFFF BIT0: Analog AI1(V light on) BIT1: Analog AI2(V light on) BIT2: Analog AI3(V light on) BIT3~BIT15: Reserved	0x0000	○
F07.07	Stop Status Display Selection	0x0000~0xFFFF BIT0: Reference frequency BIT1: DC bus voltage BIT2: Input terminal status BIT3: Output terminal status BIT7: Analog AI1(V light on) BIT8: Analog AI2(V light on) BIT9: Analog AI3(V light on)	0x00FF	○
F07.08	Frequency display coefficient	0.01~10.00 Display frequency=running frequency* F07.08	1.00	○

Code	Name	Description	Factory Default	Attribute
F07.09	Rotating speed display coefficient	0.1~999.9% Mechanical speed=120*display frequency×F07.09/Number of motor pole pairs	100.0%	○
F07.10	Linear speed display coefficient	0.1~999.9% Linear speed=Mechanical speed×F07.10	1.0%	○
F07.11	Rectification bridge temperature	0~100.0°C		●
F07.12	Converting module temperature	0~100.0°C		●
F07.13	Software version	1.00~655.35		●
F07.14	Accumulative running time	0~65535h		●
F07.18	Inverter Rate Power	0.4~3000.0kW		●
F07.19	Inverter Rate Voltage	50~1200V		●
F07.20	Inverter Rate Current	0.1~6000.0A		●
F07.27	Now Fault Type	0: Not fault		●
F07.28	Latest Fault Type	1: Over-current when acceleration (OC1)		●
F07.29	The Second Fault Type	2: Over-current when deceleration (OC2)		●
F07.30	The Third Fault Type	3: Over-current when constant speed running (OC3)		●
F07.31	The Fourth Fault Type	4: Over-voltage when acceleration (OV1)		●
F07.32	The Fifth Fault Type	5: Over-voltage when deceleration (OV2) 6: Over-voltage when constant speed running (OV3) 7: DC bus Under-voltage (UV) 8: IGBT Ph-U fault (OUT1) 9: IGBT Ph-V fault (OUT2) 10: IGBT Ph-W fault (OUT3) 11: Motor overload (OL1) 12: Inverter overload (OL2) 13: overload alarm (OL3) 14: IGBT overheat (OH1) 15: Rectify overheat (OH2) 16: Input phase failure (SFI) 17: Output phase failure (SFO) 18: Brake unit fault (bCE) 19: Ground short-circuit fault (ETH) 20: Under load fault (LL) 21: Communication fault (E.485) 22: External fault (EF) 23: EEPROM fault (EEE) 24: Trial time reached (END)		●

Code	Name	Description	Factory Default	Attribute
		25: Current detection fault (ItE) 32: Short to ground fault 1(ETH1) 33: Short to ground fault 2(ETH2) 36: Low-load fault(LL) Warning: A-LS: Lack sunlight A-tF: water full A-LL: lack water source A-LL1: water source drain		
F08 Group: Auxiliary function				
F08.00	ACC time 2	0.0~3600.0s	Depend on mode	○
F08.01	DEC time 2	0.0~3600.0s	Depend on mode	○
F08.02	ACC time 3	0.0~3600.0s	Depend on mode	○
F08.03	DEC time 3	0.0~3600.0s	Depend on mode	○
F08.04	ACC time 4	0.0~3600.0s	Depend on mode	○
F08.05	DEC time 4	0.0~3600.0s	Depend on mode	○
F08.06	Jogging frequency	0.00~F00.03 (Max. frequency)	5.00Hz	○
F08.07	Jogging running ACC time	0.0~3600.0s	Depend on mode	○
F08.08	Jogging running DEC time	0.0~3600.0s	Depend on mode	○
F08.28	Fault Auto Reset Times	0~10	5	○
F08.29	Reset Interval	0.1~3600.0s	2.0s	○
F08.32	FDT1 level detection value	0.00~F00.03 (Max. frequency)	50.00Hz	○
F08.33	FDT1 lag detection	-100.0~100.0% (FDT1 level)	5.0%	○
F08.34	FDT2 level detection value	0.00~F00.03 (Max. frequency)	50.00Hz	○
F08.35	FDT2 lag detection	-100.0~100.0% (FDT2 level)	5.0%	○
F08.36	Frequency arrival detective value	0.00~F00.03 (Max. frequency)	0.00Hz	○
F08.37	Energy consumption brake enable	0: brake disable 1: brake enable	0	○
F08.38	Braking threshold voltage	200.0~2000.0V(220V voltage:380.0V)	Depend on voltage	○
		200.0~2000.0V(380V voltage:700.0V)		
		200.0~2000.0V(660V voltage:1120.0V)		
F08.39	Running mode of cooling fan	0: normal running mode 1: keep running after power on	0	○

Code	Name	Description	Factory Default	Attribute
F09 Group: Reserved				
F10 Group: Reserved				
F11 Group: Protective parameter				
F11.00	Phase loss protection	0x00~0x11 LED ones place: 0: input phase loss protection disabled 1:input phase loss protection enabled LED tens place: 0: output phase loss protection disabled 1:output phase loss protection enabled	10 (CT112-4T) 00 (CT112A) (CT112-2S)	○
F11.01	Frequency decreasing point at sudden power loss	00.0~100.0% (standard bus voltage)	80.0%	○
F11.02	Frequency decreasing ratio at sudden power loss	0.00Hz~F00.03 (Max. frequency)	15.00Hz/s	○
F11.03	Overvoltage stall selection	0: disabled 1: enabled	0	○
F11.04	Overvoltage stall protection voltage	380V: 120~150%(standard bus voltage)	140%	○
		220V: 120~150%(standard bus voltage)	120%	
F11.05	Overcurrent stall actuation selection	0x00~0x11 Ones place:actuation selection 0: Current limit actuation selection 1:actuation always valid Tens place:hardware current limit over-load alarm selection 0:hardware current limit over load alarm valid 1:hardware current limit over load alarm invalid	01	☆
F11.06	Overcurrent stall protection current	50.0%~200.0%	160.0%	☆
F11.07	Overcurrent stall frequency decreasing ratio	0.00~50.00Hz/s	10.00Hz/s	☆
F11.08	Over(under)load warning actuation selection	0x000~0x131 Ones place: 0: motor over(under)load early alarm,relative to motor rated current 1: inverter over/under load early alarm,relative to inverter rated current	0x000	○

Code	Name	Description	Factory Default	Attribute
		Tens place: 0: inverter keeps running after over/under load alarm 1: inverter keeps running after under-load alarm and stops after over-load alarm 2: inverter keeps running after over-load alarm and stops after under-load alarm 3: inverter stops after over/under load alarm Hundreds place: 0: detecting all the way 1: detecting during constant running		
F11.13	Fault output terminal actuation selection	0x00~0x11 Ones place: 0: action when under-voltage fault appears 1: no action when under-voltage fault appears Tens place: 0: action during automatic resetting 1: no action during when automatic resetting	0x00	○
F11.16	Automatic frequency reduction selection of Voltage fallen-down	0: invalid 1: valid	1	○
F14 Group: Communication				
F14.00	Local address	0 is the broadcast address, 1~247 are slave addresses	1	○
F14.01	Baud rate	0: 1200bps 1: 2400bps 2: 4800bps 3: 9600bps 4: 19200bps 5: 38400bps 6: 57600bps	4	○
F14.02	Data check	0: no check (N, 8,1) for RTU 1: even check (E, 8,1) for RTU 2: odd check (O, 8,1) for RTU 3: no check (N, 8,2) for RTU 4: even check (E, 8,2) for RTU 5: odd check (O, 8,2) for RTU	1	○
F14.03	Response delay	0~200ms	5	○
F14.04	Communication timeout detection time	0.0 (invalid), 0.1~100.0s	0.0S	○

Code	Name	Description	Factory Default	Attribute
F14.05	Communication timeout error handling	0: alarm and coast to stop 1: no alarm and continue running 2: no alarm and stop according to stop mode (communication mode is valid) 3: no alarm and stop according to stop mode (all control modes are valid)	0	○
F14.06	Communication processing actuation selection	LED ones 0: write with response 1: write without response LED tens 0: set value unsaved after power off 1: set value saved after power off	0x00	○
F15 Group Solar inverter special function				
F15.00	PV Inverter Selection	0: Disabled 1: Enabled 2: Boost enabled (CT112A special)	1 (CT112) 2 (CT112A)	○
F15.01	Vmpp Voltage Selection	0: Constant Voltage 1: Max. Power Point Tacking(MPPT) 2: Bus voltage *0.85	1	○
F15.02	Vmpp Voltage Keypad Set	0.0~6553.5Vdc	555.0V or 200.0V Depend on mode	○
F15.03	PID Off Set Limits	0.0~100.0%(100.0% refer P11.18)	0.0%	☆
F15.04	PID Max. Output Frequency	0~100.0%	100.0%	○
F15.05	PID Min. Output Frequency	0.0%~100.0%	0.0%	○
F15.06	KP1	0.00~100.00	1.0 (CT112) 10.0 (CT112A)	○
F15.07	KI1	0.00~100.00	1.0 (CT112) 10.0 (CT112A)	○
F15.08	KP2	0.00~100.00	15.00 (CT112) 10.00 (CT112A)	○
F15.09	KI2	0.00~100.00	15.00 (CT112) 10.00 (CT112A)	○

Code	Name	Description	Factory Default	Attribute
F15.10	PI Amplitude	0.0~6553.5Vdc	25.0V /30.0V /60.0V Depend on mode	○
F15.11	Dry Pump Function	0: Disabled 1: Enabled	1	○
F15.12	Dry-Water Threshold	0.0~100.0%	0.0%	○
F15.13	Delay Time of Dry-Water	0~3600.0s	60.0s	○
F15.14	Wake-up Delay Time of Dry-Water	0~3600.0s	600.0s	○
F15.15	POWER SELECT	0: motor 1: UI	0	○
F15.16	Over-heat reduced frequency	0.00~10.00Hz/°C	3.00Hz/°C	○
F15.17	Delay Time of Full-Water	0.0~3600.0s	60.0s	○
F15.18	Reset Delay of Full-Water	0.0~3600.0s	120.0s	○
F15.19	Frequency of Weak Light	0~50.00Hz	5.00Hz (CT112) 15.00Hz (CT112A)	○
F15.20	Delay Time of Weak Light	0.0~3600.0s	600.0s	○
F15.21	Reset Delay of Weak Light	0.0~3600.0s	300.0s	○
F15.22	Reference Voltage of Given Display	0.0~2000.0V	0V	●
F15.23	Min. Voltage of MPPT	0.0~6553.5Vdc	50.0V	○
F15.24	Max. Voltage of MPPT	0.0~6553.5Vdc	780.0V	○
F15.25	KP3 (CT112A special)	0.00~100.00	40.00	○
F15.26	KI3 (CT112A special)	0.00~100.00	5.00	○
F15.27	Boost Voltage set (CT112A special)	0.0~6553.5Vdc	330.0V	○
F15.28	KP4 (CT112A special)	0.00~100.00	20.00	○
F15.29	KI4 (CT112A special)	0.00~100.00	5.00	○
F17 Group: Status view function				
F17.00	Set frequency	0.00Hz~F00.03	0.00Hz	●
F17.01	Output frequency	0.00Hz~F00.03	0.00Hz	●
F17.02	Slope given frequency	0.00Hz~F00.03	0.00Hz	●

Code	Name	Description	Factory Default	Attribute
F17.03	Output voltage	0~1200V	0V	●
F17.04	Output current	0.0~5000.0A	0.0A	●
F17.05	Motor rotary speed	0~65535RPM	0 RPM	●
F17.08	Motor power	-300.0~300.0%	0.0%	●
F17.10	Solar battery voltage	0.0~2000.0V	0v	●
F17.11	DC bus voltage	0.0~2000.0V	0V	●
F17.12	Digital input terminal status	0000~00FF	0	●
F17.13	Digital output terminal status	0000~000F	0	●
F17.14	Digital adjustment	0.00Hz~F00.03	0.00V	●
F17.15	Given torque	-300.0%~300.0%	0.0%	●
F17.16	Solar battery current	0.0~2000.0A	0A	●
F17.19	AI1 input voltage	0.00~10.00V	0.00V	●
F17.20	AI2 input voltage	0.00~10.00V	0.00V	●
F17.21	AI3 input voltage	-10.00~10.00V	0.00V	●
F17.22	HDI input Frequency	0.00Hz~50.00kHz	0.00kHz	●

Chapter 5 Troubles Shooting

5.1 Main Circuit Terminals

Fault Code	P.OFF	Fault Type	Power Off
Reason	External power supply close	Solution	Check the three-phase power is off or not
Fault Code	E.Out1	Fault Type	IGBT Ph-U fault
	E.Out2		IGBT Ph-V fault
	E.Out3		IGBT Ph-W fault
Reason	Acc/Dec time is too short	Solution	Increase Acc/Dec time
	IGBT module fault		Ask for support
	Malfunction caused by interference		Inspect external equipment and eliminate interference
	Ground is not properly		
Fault Code	E.oC1	Fault Type	Over-current when acceleration
Reason	Acc time is too short	Solution	Increase Acc time
	Input voltage is too low		Check the power supply
	Capacity of inverter is too small		Select bigger capacity inverter
Fault Code	E.oC2	Fault Type	Over-current when deceleration
Reason	Dec time is too short	Solution	Increase Dec time
	Load is too heavy		Install proper external braking unit
	Capacity of inverter is too small		Select bigger capacity inverter
Fault Code	E.oC3	Fault Type	Over-current when constant speed running
Reason	Sudden change of load or abnormal	Solution	Check the load or reduce sudden change of load
	Input voltage is too low		Check the power supply
	Capacity of inverter is too small		Select bigger capacity inverter
Fault Code	E.oU1	Fault Type	Over-voltage when acceleration
Reason	Input voltage abnormal	Solution	Check the power supply
	After instant power off, restart the rotating motor		Void restart after power off
Fault Code	E.oU2	Fault Type	Over-voltage when deceleration
Reason	Dec time is too short	Solution	Increase Dec time
	Load is too heavy		Increase braking resistance /unit
	Input voltage abnormal		Check the power supply
Fault Code	E.oU3	Fault Type	Over-voltage when constant speed running
Reason	Input voltage abnormal	Solution	Install input DC reactor
	Load is too heavy		Install proper external braking unit
Fault Code	E.LU	Fault Type	DC bus Under-voltage
Reason	Input voltage is too low	Solution	Inspect the input power supply

Fault Code	E.oL1	Fault Type	Motor overload
Reason	Input voltage is too low	Solution	Inspect the input power supply
	Improper motor's overload protection threshold		Set proper motor rated current
	Motor block or sudden change of load		Check the load and adjust torque boost
	Motor drive heavy load at low speed for a long time		Select variable frequency motor
Fault Code	E.oL2	Fault Type	Inverter overload
Reason	Acc time is too short	Solution	Decrease acceleration
	Restart the rotating motor		Avoid restart after power off
	Input voltage is too low		Check the power supply
	Load is too heavy		Select bigger capacity inverter
Fault Code	E.SPI	Fault Type	Input phase failure
Reason	Phase loss of R,S,T input	Solution	1.Check power supply 2.Check the wiring installation
Fault Code	E.SP0	Fault Type	Output phase failure
Reason	Phase loss of U,V,W output (or a serious unbalance in 3phase input)	Solution	Check the wiring installation of output
	Connection loose		Check the motor and wiring
Fault Code	E.oH1	Fault Type	Rectify overheat
	E.oH2		IGBT overheat
Reason	Instant over current of inverter	Solution	Refer to over current solution
	Short-circuit or ground fault occurred at inverter output		Check the wiring and install again
	Obstruction of ventilation channel or Cooling fans of inverter stops or damaged		Clear the ventilation Channel or Replace cooling fan
	Ambient temperature is too high		Reduce Ambient temperature
	Control board wire or plug-ins loss		Check the wiring and Installation
	Auxiliary power damaged or under voltage of driver voltage		Ask for support
	Power module bridge short		Ask for support
	Control board abnormal		Ask for support
Fault Code	E.EF	Fault Type	External fault
Reason	SI External fault input terminal take effect	Solution	Inspect input of external equipment
Fault Code	E.CE	Fault Type	Communication fault
Reason	Improper baud rate setting	Solution	Set proper baud rate
	Receive wrong data		Press STOP/RESET to reset. Ask for support
	Communication is interrupted for long time		Check wiring of communication interface

Fault Code	E.lTe	Fault Type	Current detection fault
Reason	Wires or connectors of control boards are loose	Solution	Check the signal linker and insert it again
	Auxiliary power damaged		Ask for support
	Hall sensor is damaged		Ask for support
	Amplifying circuit is abnormal		Ask for support
Fault Code	E.tE	Fault Type	Motor auto tuning fault
Reason	Capacity of motor is not meet that of inverter	Solution	Change the model of inverter
	Improper setting of motor rated parameters		Set rated parameters according to motor nameplate
	The motor parameter auto-tuning are warped with the standard parameter		Run the motor without load and do auto-tuning again
	Overtime of auto-tuning		Check motor's wiring and parameters
Fault Code	E.EEP	Fault Type	EPRom fault
Reason	R/W fault of control parameters	Solution	Press STOP/RESET to Reset.
	EEPROM damaged		Ask for support
Fault Code	E.PIDE	Fault Type	Ask for support
Reason	PID feedback disconnect	Solution	Inspect PID feedback signal wire
	PID feedback source disappears		Inspect PID feedback source
Fault Code	E.bCE	Fault Type	Brake unit fault
Reason	Braking circuit failure or brake tube damaged	Solution	Inspect braking unit, replace braking tube
	Too low resistance of externally connected braking resistor		Increased braking resistance
Fault Code	E.END	Fault Type	Setting time has finished
Reason	The actual running time is beyond the setting time	Solution	Ask for support
Fault Code	E.oL3	Fault Type	Electronic overload
Reason	Load is too heavy	Solution	Check the load
	Electronic warning point is too low		Check electronic warning point
Fault Code	E.EAH1	Fault Type	Output is short-circuited to ground
Reason	One phase Output of inverter is short-circuited to ground	Solution	Check the motor wiring
	Current detect circuit is broken		Ask for support
Fault Code	E.EAH2	Fault Type	Output is short-circuited to ground
Reason	One phase Output of inverter is short-circuited to ground	Solution	Check the motor wiring
	Current detect circuit is broken		Ask for support

Fault Code	A-LS	Fault Type	Weak light
Reason	Light is too weak to keep running state	Solution	Wait for stronger sunshine
Fault Code	A-tF	Fault Type	Full water
Reason	Water is adequate	Solution	Wait for clearing alert
Fault Code	A-LL	Fault Type	Water shortage
Reason	Water sources are lacking of water	Solution	Wait for clearing alert
Fault Code	A-LL1	Fault Type	Water shortage
Reason	Water sources are lacking of water	Solution	Wait for clearing alert

5.2 Common faults and solutions

The drive may have following faults or malfunctions during operation, please refer to the following solutions.

No display after power on:

Inspect whether the voltage of power supply is same as the inverter rated voltage or not with multi-meter. If the power supply has problem, inspect and solve it. Inspect whether the 3 phase rectify bridge is in good condition or not. If the rectification bridge is burst out, ask for support.

Check the CHARGE light. If the light is off, the fault is mainly in the rectify bridge or the buffer resistor. If the light is on, the fault may be lies in the switching power supply. Please ask for support. Power supply air switch trips off when power on:

Inspect whether the input power supply is grounded or short circuit. Please solve the problem. Inspect whether the rectify bridge has been burnt or not. If it is damaged, ask for support.

Motor doesn't move after inverter running:

Inspect if there is balanced three-phase output among U, V, W. If yes, then motor could be damaged, or mechanically locked. Please solve it.

If the output is unbalanced or lost, the inverter drive board or the output module may be damaged, ask for support.

If there is not output voltage, the drive board or the output module may be damaged. Ask for support.

Inverter displays normally when power on, but breaker switch at the input side trips when running: Please check whether inverter or motor has short circuit or wrongly connecting earth.

If the breaker is occasionally switch off and the distance is too long between motor and inverter, please consider to add AC output choke.

Chapter 6 Warranty

6.1 Warranty

The warranty of this inverter is 18 months, or we provide 2% spare parts for free. When any fault or damage occurs on the product, within the warranty period, our company will provide free maintenance. After the warranty time, we can provide lifetime paid warranty service.

6.2 Supplementary

In order to enjoy better after-sales service, please pay attention to the following:

Provide below information when inquiry, we will make good configuration for you.		
1	Pump	Power, Voltage, Phase
2	Solar Panel	Each panel power, voc voltage, vmp voltage
Provide below photo and information after installation.		
1	Pump	Photos show pump, pump specification, pump and inverter connection
2	Inverter	Photos show inverter installation environment inverter connection and switch, LCD screen parameter setting.
3	Solar Panel	Photos show solar panel and inverter connection, solar panel specification, solar panel array and quantity.

Prompt: Warranty only covers the body of the inverter

6.3 Warranty agreement

- The warranty of this inverter is 18 months, or 2% spare parts for free. When any fault or damage occurs on the product, within the warranty period, our company will provide free maintenance. After the warranty time, we can provide lifetime paid warranty service.
- The warranty time starts from the date when the product is leaving the factory, and the machine frame code is the only proof to determine the warranty period.
- Certain maintenance charge should be considered during warranty period if the fault is caused by the following reason:
 - Fault caused by operating against the manual or surpass the standard specification
 - Fault caused by self fix and modification without permission.
 - Fault caused by poor preservation
 - Fault by using the inverter in malfunction
 - Machine damage caused by fire, salt corrosion, gas corrosion, earthquake, storm, lightning, abnormal voltage or other force majeure.
- Please be sure to retain this card and show it to the maintenance service.

Chapter 7 Communication protocol

The CT112&CT112A series inverters provide RS485 communication interface. You can realize centralized control via PC/PLC (set the run commands and function parameters of the inverter, read the work state and fault information of the inverter) to meet the specific requirements.

1. Content

The serial communication protocol defines the content and format of the transmission information for serial communication, including master polling (or broadcast) format, master encoding method including the required function codes, transmission data and error check. The slave response also uses the same structure including actuation confirmation, return data and error check. If an error occurs when the slave receives information or the slave cannot complete the actuation required by the master, it will feedback a response of fault information to the master.

2. Application mode

The inverter has access to "single- master multi-slaves" PC/PLC control network with RS485 bus.

Support Modbus protocol and RTU format; broadcast address is 0 and slave address can be set to 1~247.

3. Bus structure

(1) interface mode

RS485 (CT112 terminals: 485 + and 485-) hardware interface

(2) transmission mode

Asynchronous serial, half duplex transmission. At the same time, only one can send data and the other can receive data for the master and the slave. Data in the serial asynchronous communication process, in the form of a message, can be sent one by one frame.

(3) topology structure

Single-master multi-slaves network, the slave address in the network must be unique.

4. Description of the protocol

CT112&CT112A series inverter communication protocol is an asynchronous serial master-slave Modbus communication protocol and only one device (master) in the network can establish a protocol (called "query/command"). Other devices (slaves) can only provide data to respond to the master's "query/command" or make the corresponding actuation according to the master's "query/command". The master refers to a personal computer (PC), an industrial control device or a programmable logic controller (PLC), etc. The slave is inverter. The master can communicate with a single slave as well as send a broadcast message to all slaves. For the master's single "query/command", the slave has to return a message (called a response), for the master's broadcast message, the slaves do not need to respond to the master.

5. Communication data format

The Modbus protocol communication data format of CT112 series inverters is as follows:

In RTU mode, the minimum interval time should be at least 3.5 bytes for message transmission, which is the easiest way to achieve a variety of character time at the baud rate. The first transmitted field is the device address. The transmitted characters can be hexadecimal 0...9 and A...F. The network device constantly detects the network bus, even during the interval time. When the first field (address field) is received, the corresponding device decodes next transmitting character. After the last transmitting character, the interval time of at least 3.5 bytes marks the end of the message. A new message can start after this pause.

The whole message frame is a continuous transmitting flow. If there is an interval time of more than 1.5 bytes before the frame is completed, the receiving device will renew the uncompleted message and assume that the next byte is the address field of a new message. As such, if the new message follows the previous message within the interval time of 3.5 bytes, the receiving device will deal with it as the same with the previous message. If these two phenomena all happen during the transmission, the CRC will generate a fault message to respond to the sending devices.

RTU frame format

START	Interval time of 3.5 bytes
ADR	Communication address: 1~247
CMD	03: read slave parameters; 06: write slave parameters
DATA (N-1)	Function parameter address, function parameter number, function parameter value etc.
DATA (N-2)	
.....	
DATA (0)	
CRC CHK low bit	Detection value: CRC
CRC CHK high bit	
END	Interval time of 3.5 bytes

CMD (command instruction) and DATA

Command code: 03H, read N words (at most 16 words can be read)

For example: the baud rate 19200bps, even check (E, 8,1) for RTU, read continuous two data from the inverter F06.19 with the slave address of 01.

Master command message

ADR	01H
CMD	03H
High bit of start address	06H (Function code group)
Low bit of start address	13H (Function code bit)
High bit of register number	00H
Low bit of register number	02H
Low bit of CRC CHK	35H
High bit of CRC CHK	46H

Slave response message

ADR	01H
CMD	03H
The number of bytes	04H
High bit of F06.19 data	00H
Low bit of F06.19 data	00H
High bit of F06.20 data	03H
Low bit of F06.20 data	E8H
Low bit of CRC CHK	FAH
High bit of CRC CHK	8DH

Command code: 06H, write a word

For example: the baud rate 19200bps, even check (E, 8,1) for RTU, write 40.00Hz

(communication without decimal point) (0FA0H) to F00.09H address of the inverter whose slave address is 02H, and change the keypad set frequency to 40.00Hz.

Master command message

ADR	02H
CMD	06H
High bit of F00.09 address	00H (Function code group)
Low bit of F00.09 address	09H (Function code bit)
High bit of F00.09 data	0FH
Low bit of F00.09 data	A0H
Low bit of CRC CHK	5CH
High bit of CRC CHK	73H

Slave response message

ADR	02H
CMD	06H
High bit of F00.09 address	00H (Function code group)
Low bit of F00.09 address	09H (Function code bit)
High bit of F00.09 data	0FH
Low bit of F00.09 data	A0H
Low bit of CRC CHK	5CH
High bit of CRC CHK	73H

Check mode-CRC (Cyclical Redundancy Check) check

The checkout uses RTU frame format. The frame includes the frame error detection field which is based on the CRC calculation method. The CRC field is two bytes including 16 figure binary values. It is added into the frame after calculated by transmitting device. The receiving device recalculates the CRC of the received frame and compares them with the value in the received CRC field. If the two CRC values are different, there is an error in the communication.

Using the RTU frame format, the message includes an error detection field based on the CRC method. The CRC field detects the contents of the entire message. The CRC field is two bytes and contains a 16-bit binary value. It is added to the message by the transmission device. The receiving device recalculates the CRC of the received message and compares it with the value in the received CRC field. If the two CRC values are not equal, the transmission has an error.

During CRC, 0*FFFF will be stored. And then, deal with the continuous 6-above bytes in

the frame and the value in the register. Only the 8Bit data in every character is effective to CRC, while the start bit, the end and the odd and even check bit is ineffective.

The calculation of CRC applies the international standard CRC checkout principles. When you are editing CRC calculation, you can refer to the relative standard CRC calculation to write the required CRC calculation program.

Here provided a simple function of CRC calculation for the reference (programmed with C language)

```
unsigned int crc_cal_value(unsigned char*data_value,unsigned char data_length)
{
int i;
unsigned int crc_value=0xffff;
while(data_length--)
{
crc_value^=*data_value++;
for(i=0;i<8;i++)
{
if(crc_value&0x0001)
crc_value=(crc_value>>1)^0xa001;
else
crc_value=crc_value>>1;
}
}
return(crc_value);
}
```

Fault message response

The slave uses functional code fields and fault addresses to indicate it is a normal response or some error occurs (named as objection response). For normal responses,

the slave shows corresponding function codes, digital address or sub-function codes as the response. For objection responses, the slave returns a code which equals the normal code, but the first byte is logic 1.

For example: when the master sends a message to the slave, requiring it to read a group of address data of the inverter function codes, there will be following function codes:

0 0 0 0 0 1 1 (hexadecimal 03H)

For normal responses, the slave responds the same function codes, while for objection responses, it will return:

1 0 0 0 0 1 1 (hexadecimal 83H)

Besides the function codes modification for the objection fault, the slave will respond a byte of abnormal code which defines the error reason.

When the master receives the response for the objection, in a typical processing, it will send the message again or modify the corresponding order.

Error code and meaning

Modbus abnormal code		
Code	Name	Meaning
01H	Illegal command	The command from master cannot be executed. This command is only for new version and this version cannot realize. Slave is in fault state and cannot execute it.
02H	Illegal data address	Some of the operation addresses are invalid or not allowed to access. Especially the combination of the register and the transmitting bytes are invalid.
03H	Illegal value	When there are invalid data in the message framed received by slave. Note: This error code does not indicate the data value to write exceed the range, but indicate the message frame is an illegal frame.
06H	The slave is busy	Inverter is busy (EPPROM is in storage)
10H	Password error	The password written to the password check address is not the same as the password set by P7.00.
11H	Check error	In the frame message sent by the upper monitor, the length of the digital frame is incorrect or the counting of CRC check bit in RTU is different from the lower monitor.

Modbus abnormal code		
Code	Name	Meaning
12H	Invalid parameter change	It only happens in write command. The written data exceeds the parameter range. The parameter should not be modified now. The terminal has already been used.
13H	The system is locked	When the upper computer is reading or writing and the user password is set without password unlocking, it will report that the system is locked.

Address definition of communication parameters

It is used to control the inverter operation, inverter status and related parameter settings.

Read and write function parameters (some function codes cannot be changed, only for manufacturers to use):

The rules of parameter address of the function codes:

High byte: group number before the radix point of the function code (00~15) Group 0 to Group 15

Low byte: the number after the radix point (00~FF)

For example, the parameter address of F13.17 is 0D11H.

Note: Some parameters cannot be changed when the inverter is in the running state and some parameters cannot be changed in any state. The setting range, unit and relative instructions should be paid attention to when modifying the function code parameters.

Besides, EEPROM is stored frequently, which may shorten the usage time of EEPROM. Some functions are not necessary to be stored on the communication mode. The needs can be met on by changing the value in RAM. Changing the high bit of the function code from 0 to 1 can also realize the function. The corresponding function code address is as follows:

High byte: 00~0F

Low byte: 00~FF

For example, F03.12 is not stored in EEPROM, the address is 830CH; the address can only write RAM and cannot read, read for the invalid address.

485 communication address

Function instruction	Address definition	Data meaning instruction	R/W characteristics
Communication control command	2000H	0001H: forward running	W/R
		0002H: reverse running	
		0003H: forward jogging	
		0004H: reverse jogging	
		0005H: stop	
		0006H: freewheel stop	
		0007H: fault reset	
		0008H: jogging stop	
Inverter status	2100H	0001H: forward running	R
		0002H: reverse running	
		0003H: stop	
		0004H: fault	
		0005H: -E.Lv- status	
The address of the running /stopping parameter	3000H	Running frequency (0~Fmax, unit 0.01Hz)	R
	3001H	Set frequency (0~Fmax, unit 0.01Hz)	R
	3002H	Bus voltage	R
	3003H	Output voltage	R
	3004H	Output current	R
	3005H	Running speed	R
	3006H	Output power	R
	3007H	Reserved	R
	3008H	Reserved	R
	3009H	Reserved	R
	300AH	Input terminal status (000 to 0FF, unit 01H)	R
	300BH	Output terminal status (00 to 0F, unit 01H)	R
	300CH	Analog AI1(0.00~10.00V, unit 0.01V)	R
	300DH	Reserved	R
	300EH	Reserved	R
	300FH	Reserved	R
	3010H	Reserved	R
	3011H	Reserved	R
	3012H	Reserved	R
3013H	Reserved	R	
3014H	External count number	R	
3015H	Torque set value	R	
3016H	Reserved	R	

User's Information

User Company:
Contact person:
Address:
Telephone:
Dealer company;
Post code:
Model:Serial number:
Purchase date:Handling person:



Qualification Certificate

Type of product _____

Checked by _____



Test date _____

This product has been strictly
quality-chenked and granted for delicery

